

MAX. OPERATING WEIGHT: 23.14 tonnes MAX. HORSEPOWER: 116 kW

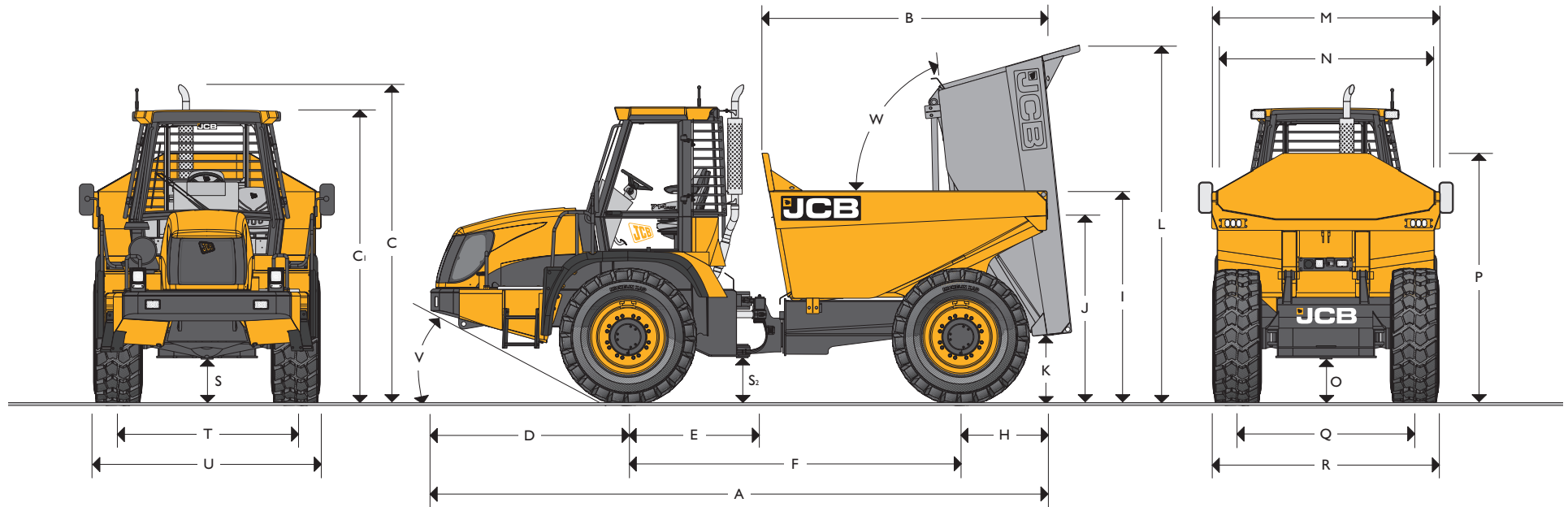

## STATIC DIMENSIONS

	mm		mm
A Overall length	6780	N Max. internal body width	2370
B Body length	3122	O Max. ground clearance (rear diff)	457
C Max. height	3425	P Max. body height to spill guard	2688
C <sub>i</sub> Height to top of cab	3180	Q Wheel track (rear)	1955
D Front axle to front bumper	2167	R Overall width (rear)	2500
E Front axle to rear of front unit	1250	S Max. ground clearance (front diff)	457
F Wheelbase (front axle to rear axle)	3653	S <sub>2</sub> Ground clearance	425
H Rear axle to rear of body	960	T Wheel track (front)	1955
I Height to top of body	2276	U Overall width (front)	2500
J Height to lip of body	1988	V Departure angle (front)	degrees 26.5
K Min. height to body when tipped	700	W Body tip angle	degrees 84
L Max. height to body when tipped	3887	Load capacity	tonnes 13.14
M Max. external body width	2502	Body – heaped	m <sup>3</sup> 7.35
		Body – struck	m <sup>3</sup> 5.7

Overall dimensions based on an unladen machine equipped with Michelin 20.5 R25 XADN tyres.

**ENGINE**

Type	6 cylinder direct injection diesel	
Model	QSB 6.7	
Capacity	litres	6.7
Bore	mm	107
Stroke	mm	124
Aspiration	Turbo charged/charge cooled	
Cylinders	6	
<b>Power rating</b>		
Max. power	kW (HP) @ 2000 rpm	123 (165)
Gross power to SAE J1995/ISO 14396	kW (HP) @ 2200 rpm	119 (160)
Net power to SAE J1349/EEC80/1269	kW (HP) @ 2200 rpm	114 (153)
<b>Torque rating</b>		
Max. torque	Nm @ 1400 rpm	732
Net torque	Nm @ 1400 rpm	710

**TRANSMISSION**

<b>Transmission</b>	Type	Smoothshift
	Make	ZF
	Model	6WG160
<b>Torque converter</b>	Type	Single stage
	Torque converter ratio	1.91:1

**AXLES**

Type	Limited slip differential
Make	ZF
Model	MT-L 3075 II
Overall axle ratio	20.365:1
Brakes	Oil immersed

**TRAVEL SPEEDS**

Assumes fitment of Michelin 20.5 R25 tyres		<b>kph</b>
<b>Forward</b>	First	5.5
	Second	8.5
	Third	12.9
	Fourth	19.6
	Fifth	28.6
	Sixth	41.5
<b>Reverse</b>	First	5.8
	Second	13.6
	Third	30.0

**HYDRAULICS**

<b>Steering and tipping</b>	Pump type		Gear
	Pump: max flow @ 2200rpm	l/min	114
	Pump: max pressure	bar	207
<b>Braking</b>	Pump type		Gear
	Pump: max flow @ 2200rpm	l/min	17.6
	Pump: max pressure	bar	175

**SERVICE FILL CAPACITIES**

	<b>litres</b>
Hydraulic system	150
Fuel tank	211
Engine oil sump	16.3
Transmission system	35
Axle oil (front)	33
Axle oil (rear)	33
Engine coolant system	30

**ELECTRICAL SYSTEM**

System voltage	Volt	24
Alternator output	Amp hour	70
Battery capacity	Amp hour	2 x 110

**BODY**

Tipping angle	degrees	84
Body plate thickness (front)	mm	6
Body plate thickness (side)	mm	6
Body plate thickness (bottom/chute)	mm	6
Yield strength	N/mm <sup>2</sup>	1000
Tensile strength	N/mm <sup>2</sup>	1245
Hardness (min)	HB	400
Body raise (laden)	seconds	9.7
Body lower (laden)	seconds	10.0
Scow angle	degrees	25.0

## TURNING CIRCLE

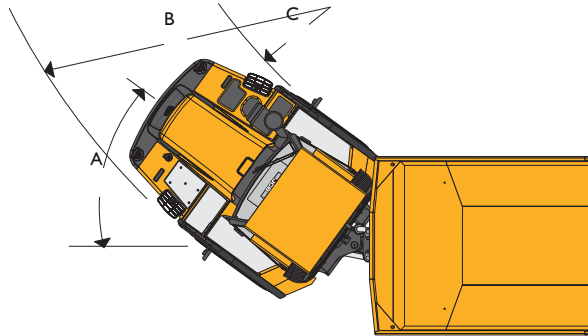

		mm
A	Articulation angle	degrees
B	Clearance radius	7100
C	Turning radius	4175

## OPERATING WEIGHTS

		Unladen	Laden
Front Axle	tonnes	7.26	10
Rear Axle	tonnes	3.67	13.7
Total	tonnes	10.91	23.7

Includes operator (80kg) and a full fuel tank.

## CHANGES TO GROUND BEARING PRESSURES

Manufacturer	Tyre Size	Type	Unladen		Laden		Tyre Pressure	
			Front	Rear	Front	Rear	Front	Rear
			kPa (PSI)	kPa (PSI)	kPa (PSI)	kPa (PSI)	kPa (PSI)	kPa (PSI)
Michelin	20.5 R25	XADN	91 (13)	46 (7)	126 (18)	172 (25)	214 (31)	345 (50)
Michelin	650/65 R25	XAD	76 (11)	39 (6)	105 (15)	144 (21)	215 (31)	346 (50)
Goodyear	650/65 R25	GP-3D	72 (10)	36 (5)	99 (14)	136 (20)	240 (35)	350 (48)
Nokian	750/55 R25	TRSL5-2	65 (9)	33 (5)	89 (13)	122 (18)	152 (22)	276 (40)

Ground bearing pressure @ 15% sinkage.

## CHANGES TO OPERATING DIMENSIONS

Manufacturer	Tyre Size	Type	Dimensional changes				Operating weight
			U	T	R	Q	
			mm	mm	mm	mm	kg
Michelin	20.5 R25	XADN	0	0	0	0	0
Goodyear	650/65 R25	GP-3D	+83	-40	+83	-40	+600
Michelin	650/65 R25	XAD	0	-85	0	-85	+608
Nokian	750/55 R25	TRS LS-2	+245	0	+245	0	-232

## RETARDATION CURVE

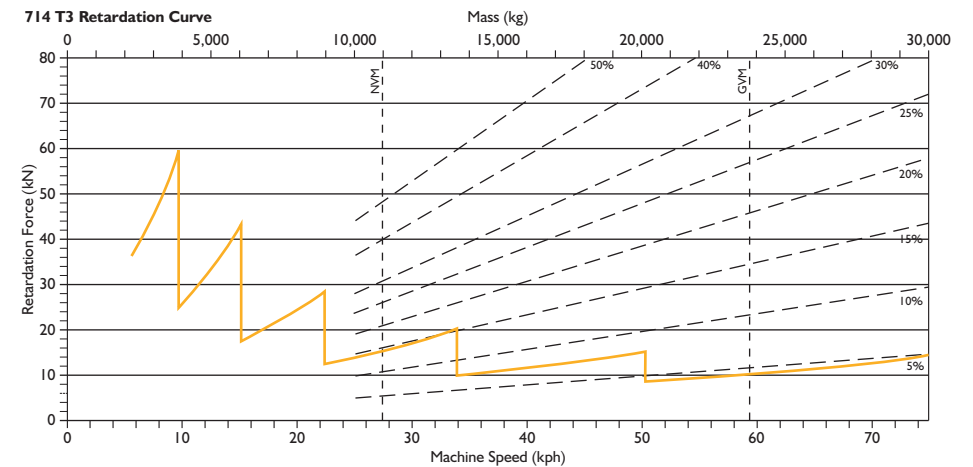

## STANDARD EQUIPMENT

**Engine:** 6 cylinder, direct injection diesel engine. Wastegate turbocharger charged cooler for maximum torque and minimum exhaust smoke. 3 stage dry type-cyclonic air cleaner with primary and safety elements. Stainless steel exhaust system.

**Transmission:** 6 forward and 3 reverse speed remote mount smoothshift transmission with integral torque converter. Manual or automatic selection. Electrical 2/4 wheel drive selection.

**Axles:** Pad mounted to the chassis. Limited Slip Differential in both axles. Planetary wheel hub reduction.

**Steering:** Double acting hydrostatic system. Priority steer valve. Emergency steering via a ground driven pump.

**Brakes:** Dual circuit, hydraulic power dry disc type with braking on all four wheels. Electrically operated dry disc parking brakes on the driveline, spring applied and hydraulically released. Brake disc guards.

**Hydraulics:** Twin gear pump system comprising main pump for priority steer and body tip, and a second pump for braking. Emergency steer via a ground driven pump.

**Cab:** ROPS and FOPS safety structure. Fully adjustable air suspension seat. Adjustable steering column. Air conditioning. Laminated safety glass. Electronic monitoring panel with LCD message display which includes body up warning light. Front & rear screen wash / wipe. 3 speed heater / demisting with replaceable air filter. LH & RH opening doors. Single lever transmission selector. Single lever hydraulic tip control. Combination stalk controls for lights, wipers, horn, direction indicators. Separate side consul for auxiliary switches. Interior light, sun visor, external rear view mirrors, and operator's storage facilities.

**Electrical:** Road lights front and rear, front working lights, reversing alarm and light, rear fog lights, horn, battery isolator, beacon, radio fittings, 70 amp alternator.

**Bodywork:** Flexible front steps, non-slip walkways, recovery hitch, lifting lugs, engine access cover. Rear cab mounted spill guard. Cast 360 deg centre hitch.

**Body:** Constructed from high strength steel with large box section stiffeners. Large target area and load retention. Two single stage double acting cylinders located within rear chassis.

## OPTIONAL EQUIPMENT

Reversing camera; Biodegradable hydraulic oil; Smart reverse alarm; 3" seat belt; Mechanical tail gate; Fire extinguisher; 24 – 12 volt in cab converter; Air suspension seat with lumbar support; Body front extension plate; Number plate kit; LiveLink telematics.

